



NUBIS MWN 130-NC

Propeller flow sensor with horizontal rotor
axis DN40 to DN300

NUBIS MWN 130-NC

The product is a propeller flow sensor intended for heat meters, with a horizontal rotor axis, aligned in parallel to the water piping centre line, and a low startup threshold. The latest engineering and processing design solutions applied in the product provide reliable readings and facilitate integration in non-standard installation configurations, including intermediate orientations between the horizontal and vertical ones, without any impact on the metrological ratings.

Application

MWN 130-NC is a propeller flow sensor intended for integration with an indicating calculator of a heat meter. The propeller flow sensor can be applied in water metering systems with the medium temperature between 0.1°C and 130°C and a maximum operating pressure of the medium at 16 bars (PN 16). The propeller flow sensor can be installed in horizontal piping (H) with the counter upward or in vertical or tilted piping (V) with the counter to the side - or at any orientation in between the two (H/V) — of heat supply systems at multi-family houses or industrial facilities

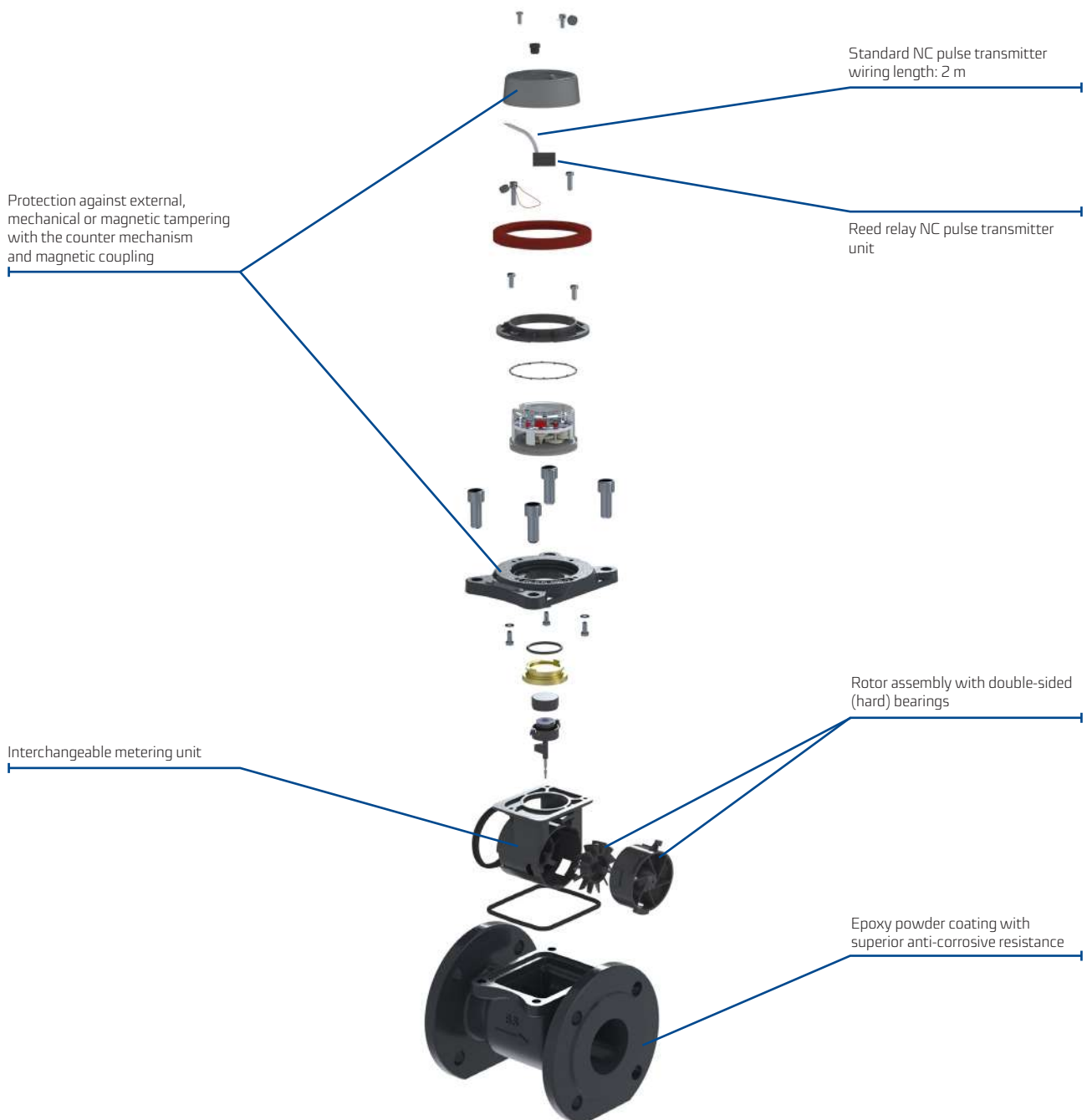

Advantages

Safety:

- protection against:
 - magnetic field tampering (anti-magnetic shields),
 - mechanical tampering (counter cover).

Convenience of use:

- easy installation,
- modular design.

Reliability:

- robust, heavy-duty design,
- unified interchangeable metering unit,
- high anti-corrosive and damage resistance performance of the paint coat (made by epoxy powder coating).

Key features

- wide measurement range with a low starting threshold,
- hard propeller bearings,
- environmental class C,
- hermetically sealed dial and barrel counter,
- counter mechanism rotation lock at 360° of turn,
- easy reading by freely rotating the counter at any orientation,
- resistant to external magnetic fields Low pressure loss.

Regulatory and standard compliance

- Directive 2014/68/EU of the European Parliament and of the Council of 15 May 2014 on the harmonisation of the laws of the Member States relating to the making available on the market of pressure equipment
- EN 1434-1:2007 Heat meters, Parts 1-6
- OIML R 75:2002 and OIML R 75:2006 Heat meters, Parts 1-3
- EC type examination certificate no. SK 11-M1004-SMU001
- Classification of environmental, climate and mechanical conditions: Class B (ref. PN-EN 14154-3:2005:A1)
- Classification of mechanical environment conditions: Class M1 (ref. Polish Regulation Dz.U. 2006.12.18)
- Classification of electromagnetic environment conditions: Class E1 (ref. Polish Regulation Dz.U. 2006.12.18)

Table 1. Technical data

Typ MWN 130-			40- NC	50- NC	65- NC	80- NC	100- NC	125- NC	150- NC	200- NC	250- NC	300- NC	
Nominal diameter	DN	mm	40	50	65	80	100	125	150	200	250	300	
Minimum flow rate	q_i	m ³ /h	0,6	0,6	1	1,6	2,4	4	6	10	40	60	
Nominal flow rate	q_p	m ³ /h	15	15	25	40	60	100	150	250	400	600	
Maximum flow rate	q_s	m ³ /h	30	30	50	80	120	200	300	500	800	1200	
Measurement range, R	q_p/q_i	-	25	25	25	25	25	25	25	25	10	10	
Indicating range	-	m ³	10 ⁶						10 ⁷				
Resolution of reading	-	m ³	0,0005						0,005			0,05	
Maximum permitted pressure	MAP	-	PN16									PN10	
Operating pressure range	-	bar	od 0,3 do 16									od 0,3 do 10	
Maximum pressure loss	ΔP	-	$\Delta P_{10} = (0,10 \text{ bar})$										
Temperature range:	-	-	$\theta \text{ min} = 0,10^\circ\text{C}$, $\theta \text{ max} = 130^\circ\text{C}$										
Minimum upstream/ downstream straight-line piping length	-	mm	0										
Operating orientation	-	-	H,V										
Maximum permitted error (accuracy class 3)	E_f	%	$\pm(3+0,05 q_p/q_i)$ and up to $\pm 5\%$										
Environmental class	-	-	C										
Reed relay NC pulse transmitter	-	dm ³ / pulse	100						1000				
Length	L	mm	200	200	200	225 200*	250	250	300	350	450	500	
Height	H	mm	65	72	83	95	105	120	135	160	193	230	
	h	mm	177	187	197	219	229	257	357	382	427	497	
	H ₁ **	mm	277	287	297	339	349	377	582	607	652	722	
	D _z	mm	150	165	185	200	220	250	285	340	400	460	
Weight		kg	8,3	10,3	11	13,7/ 14,2*	16	18,5	40,5	51,5	75,5	103,5	

* On request.

** Metering unit's removal clear height.

Flange bolt pattern: PN-EN 1092-2 (PS/PN: 10), DIN2532, DIN2501 (PN10), BS4504 (PN10);
PS/PN: 16 (to DN 200) available on request.

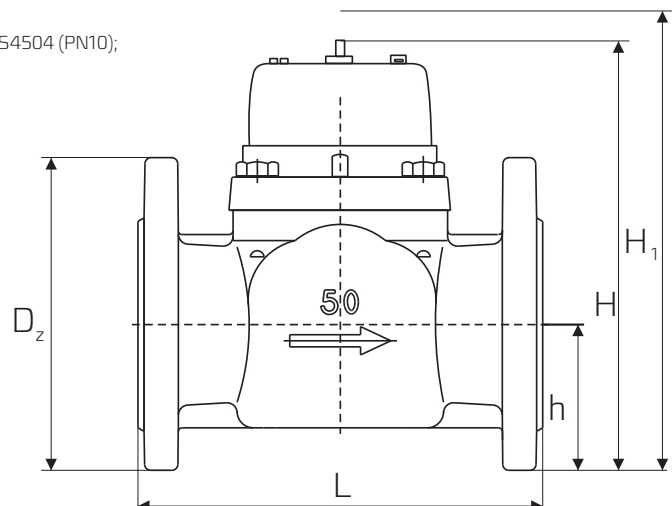

Pressure loss chart

Pressure loss

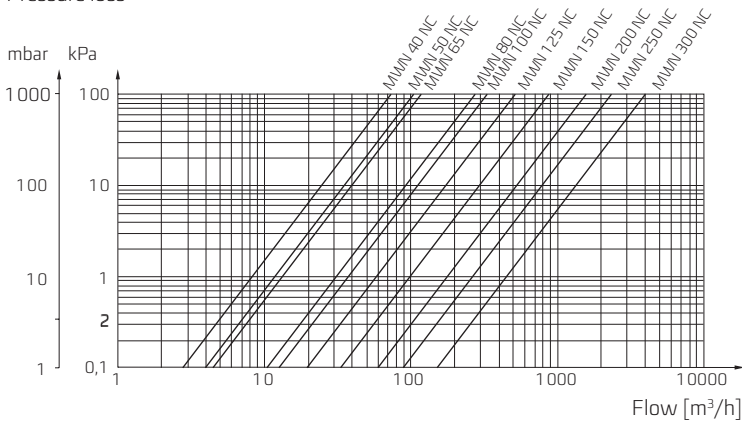

Typical error chart

Error [%]

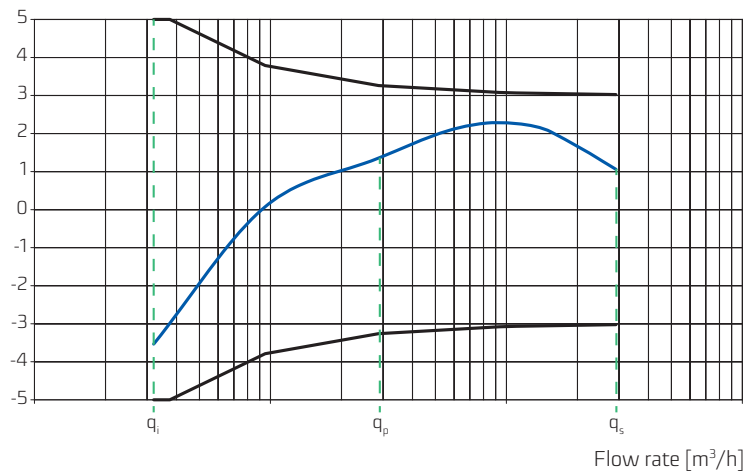

Connections for a remote transmission of readings and flow rate measurement

